

# SEPAR FILTER

## SEPAR 2000

### SWK 2000/18



POS.	ARTIKEL-NR. ARTICLE NR.	STÜCK PIECES	BENENNUNG	DESCRIPTION	POS.	ARTIKEL-NR. ARTICLE NR.	STÜCK PIECES	BENENNUNG	DESCRIPTION
1	30408	1	Entlüftungsschraube	bleed valve	11	30429	1	Zentrifuge	centrifuge
2	30452	4	Schraube(Deckel)	srew (lid)	12	30567	4	Schraube (Bowlenhaltering)	screw (for bowl retainer ring)
3	30572	1	Deckel	lid	13	30705	2	Verschluß-Stopfen	blind screw
4	30421	1	Deckeldichtung	lid (gasket)	14	30986	1	Bowle	bowl
5	30298	1	Federkassette	spring cassette	15	30472	1	Dichtung	gasket
6	01830	1	Filter-Einsatz	filter element	16	30343	1	Ablafshahn	drain cock
7	30448	8	U-Scheibe	washer	17	30560	1	Schraube	screw
8	30428	1	Gehäuse	housing	18	30558	1	Dichtung f. Pos. 1	gasket f. Pos. 1
9	30423	1	Dichtung Bowlenhaltering	bowl gasket	19	30721	2	Dichtung f. Pos. 13	gasket f. Pos. 13
10	30575	1	Bowlenhaltering	bowl retainer ring					

# SEPAR FILTER

## SEPAR 2000

SWK 2000/18

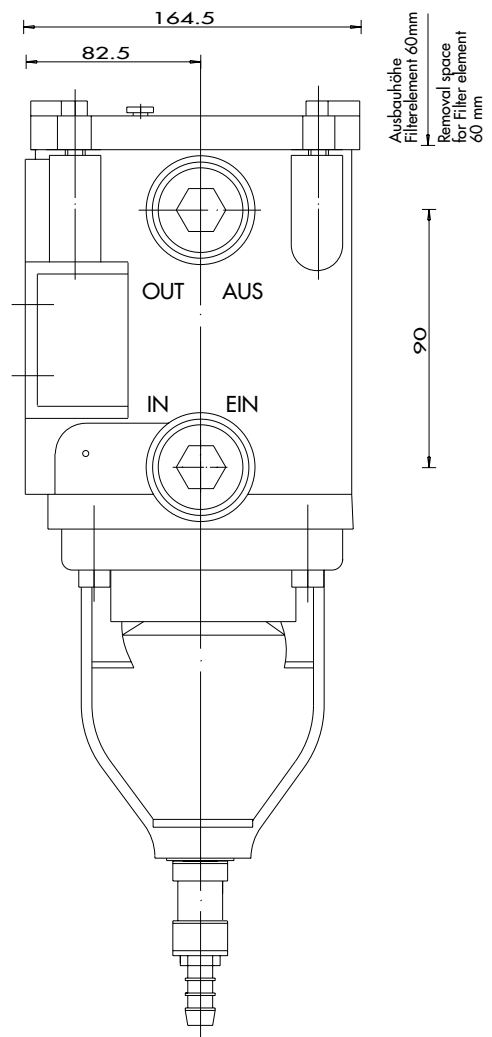
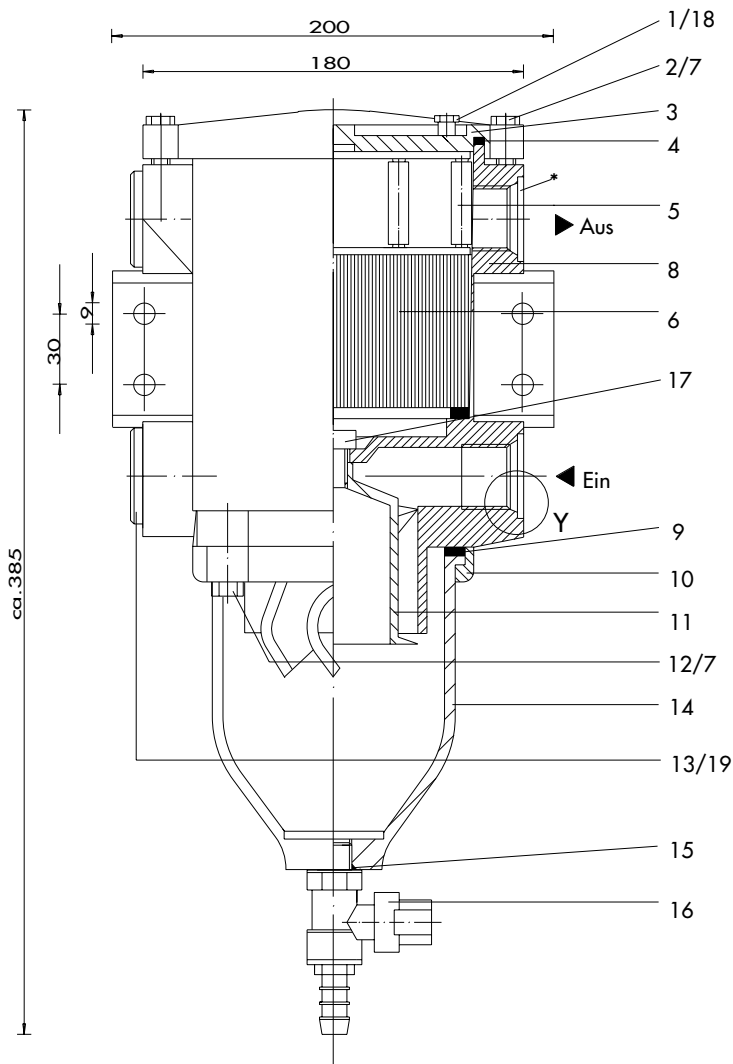

Detail Y

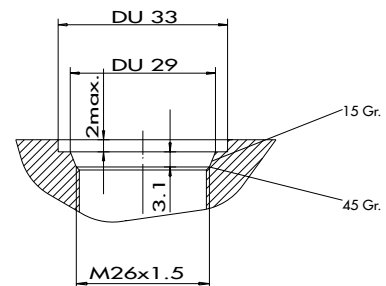

### FLUSSDIAGRAMM · FLOW DIAGRAMM

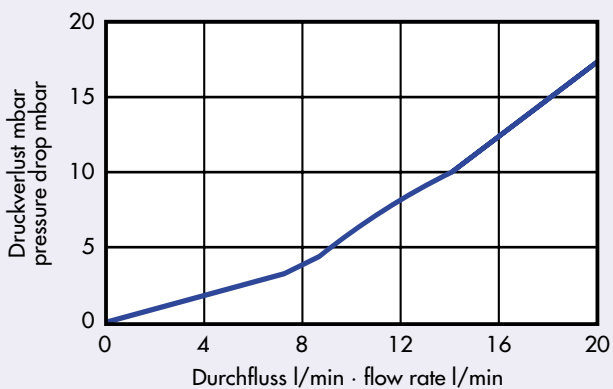

Technische Änderungen vorbehalten  
We reserve the right to make technical changes without notification

**Willibrord Lösing**  
Filter-Technik



Postfach 86 6009  
45517 Hattingen  
Essener Straße 108  
45529 Hattingen  
Telefon 023 24/9 46 00  
Telefax 023 24/408 42

Max. Durchflussmenge: 18 l/min Anschlussgewinde: M 26 x 1,5  
Max. flow rate: 18 l/min Thread: M 26 x 1,5